

## MULTISTREAM® B Solids Flow Meter



- Flow rate measurement according to the impact plate principle
- Compact design - no loss of headroom due to additional chutes
- Cost effective, simple integration - offset-free arrangement of inlet and outlet
- Dust-tight stainless steel housing
- Weighing electronics can be integrated in the mechanical system

### Application

MULTISTREAM® B Solids Flow Meters are designed as enclosed in-line measuring systems for continuous acquisition of flow rates and totalized amounts. With flow rates up to 100 t/h, or max. 80 m<sup>3</sup>/h, these measuring systems can be used for

- flow rate and consumption measurement
- totalization and
- batching

of pulverized to granular materials with a grain size of up to 30 mm. Equipped with a controllable pre-feeder, MULTISTREAM® B is also available for use as a feed system, upon request.

Its inlet/outlet arrangement without offset makes this measuring system specially suitable for economical integration into existing production plants.

### Construction

The standard equipment of MULTISTREAM® B Solids Flow Meters comprises:

- Stainless steel housing,
- Impact plate,
- Load cell, and
- Integrated electronic box.

Designed as a complete module for local operation, the ECOCONT weighing electronics can be easily accommodated in the box which is integrated in the measuring system. Of course, it is also possible to install the weighing electronics outside of the measuring system, e.g. in the control cabinet.

### Functions

Measuring systems operating according to the impact plate principle acquire the flow rate by means of a reactive force.

Guided by the inlet pipe, the material stream hits the impact plate mounted at a defined angle of inclination. The load cell and the weighing electronics acquire the horizontal component of the reactive force. Material build-ups do not affect the measuring result. Reproducible conditions of material feed, e.g. height and speed of fall or angle of impact, provide for highest accuracies.

If higher accuracies are required, check measurements are necessary which allow the measuring system to be calibrated without interrupting material flow. Requiring a presilo to be weighed, this additional equipment is available upon request.

Dimensions [mm]

MULTISTREAM® B80 Solids Flow Meter

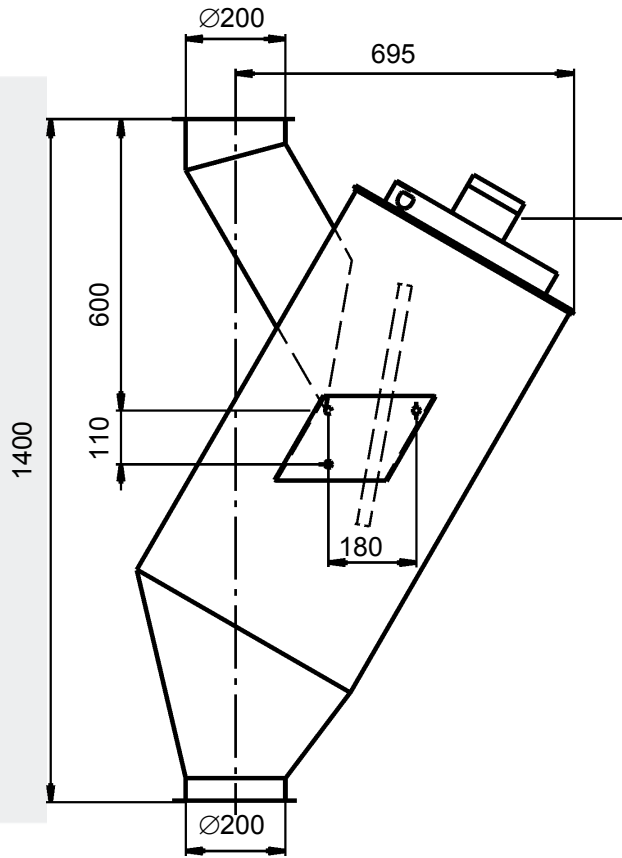

Electronic housing

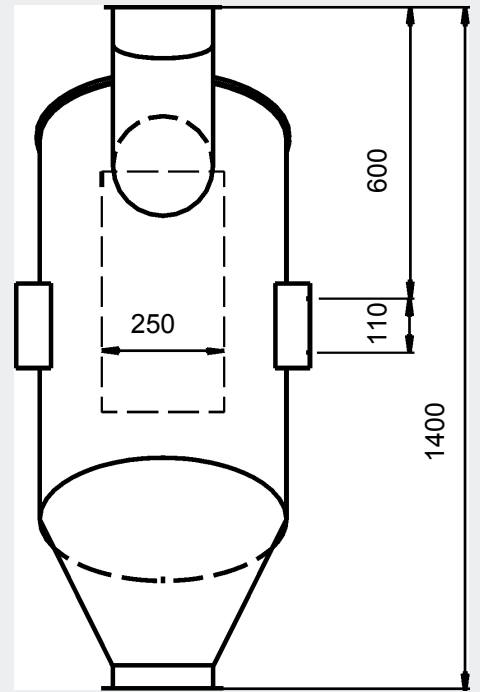

Top View

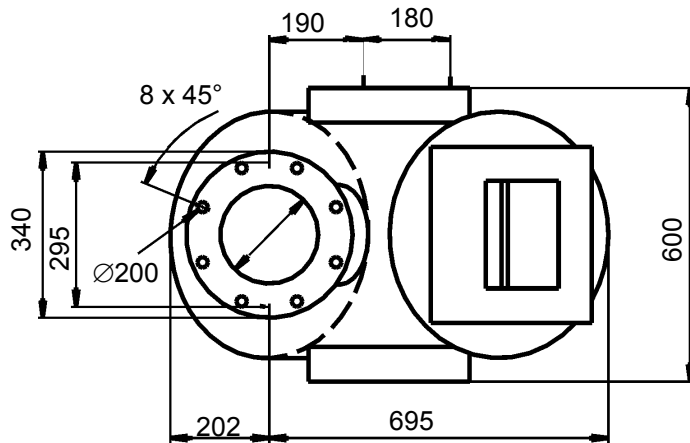

## Technical Data

	<b>MULTISTREAM® B80 Solids Flow Meters</b>
Flow rate	min. 1 t/h – max. 80 m³/h (100 t/h)
Accuracy	± 2% of nominal flow rate
Measuring range	1 : 5
Operating pressure	-25 mbar to 50 mbar
Inlet/outlet flange dimensions (DIN)	200 mm / 200 mm
Weight	50 kg
Ambient temperature	-30°C to +60°C
Material temperature	max. 70°C
Bulk density	min. 0,4 t/m³
Grain size	max. 10 mm (single grain up to 30 mm)
Flow properties	pulverized to granular, non sticky

### Accuracy

Stated accuracy relates to maximum (nominal) flow rate in the range of 20 -100% (measuring range 1:5) under the following conditions:

- Constant material properties (flow behaviour, moisture, temperature, grain size)
- System installed and calibrated in accordance with our Installation and Calibration Instructions

### Additional Requirements

Should you have additional requirements like:

- higher accuracy,
  - use as a feeding system,
- dust or gas explosion proof design, we kindly ask for a separate request.

### Order Data

To be able to process your order smoothly and quickly, please remember to indicate order numbers complete with data below:

#### Material Data

Bulk density ..... [t/m³]

Material.....

#### Flow Rate Range

From ..... [t/h]

To ..... [t/h]

Variant	Order No.
MULTISTREAM® B80, Solids Flow Meter, max. 80 m³/h	F018320.01

Documentation	Order No.
MULTISTREAM® B80 Service Manual	
German	D707380.01
English	D707381.01
French	D707382.01

One set of documentation is supplied as standard. Should you need additional copies, please order separately. Remember to indicate desired language version.