

## Compact Ring-Torsion Load Cells RTN



- OIML approved as suitable for trade use (up to 5000 d and 7500 d in case of multi-divisional scales)
- High accuracy, even for very small utilisation ranges (down to 15% in case of trade use according to OIML)
- High output signal and, thus, high-resolution of useful signal range
- Low power consumption allows realisation of multi-scale systems with simple evaluation electronics
- Protection to EEx ib IIC T 6 for use in explosion hazardous areas
- Protection class IP 68

### Application

Acting as a transducer, the load cell converts the mechanical input signal, the load, proportionally into the electrical output voltage.

The consistent optimization of the ringtorsion load cells offers additional advantages:

- The extremely low headroom simplifies the use in almost all weighing applications
- The sturdy design enables easy transport, installation, and operation, even under very harsh environmental conditions (e.g. aggressive media, interfering forces, or extreme temperatures)

### Construction

- Hermetically sealed due to laser welding; protection class IP 68
- High corrosion protection due to the use of electrolytically polished stainless steel
- All electrical components are inside the load cell and are thus optimally protected
- The high-quality, sturdy connection cable is lead radially into the load cell
- The RTN load cells are compatible with earlier ring-torsion load cells if our adapter kits are used

### Functions

- High measuring sensitivity
- High repeatability
- High long-term stability and, thus, continuing and consistently high accuracy
- Minimal effect on accuracy by side forces
- High reliability and availability, even in case of unavoidable shock loads, constraining forces or electrical interferences
- Integral excessive voltage protection
- Moment-free load input/output due to direct, vertical force flow

### RTN 1 t – 4.7 t

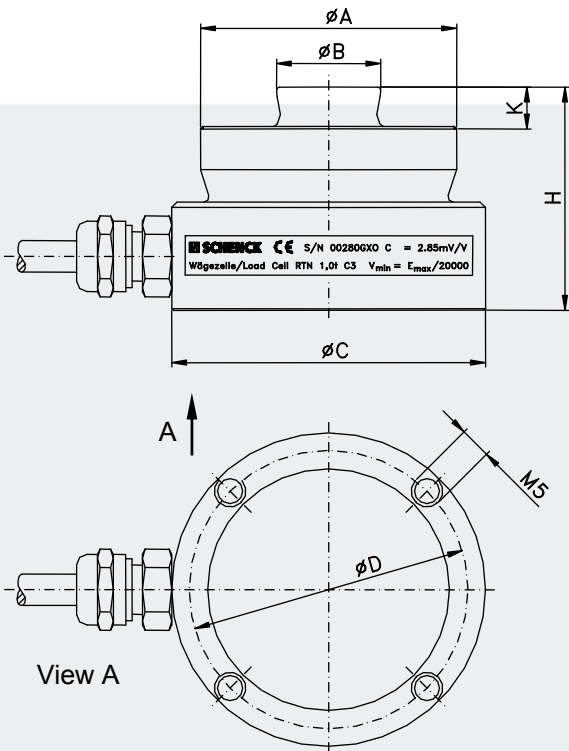

### RTN 10 t - 470 t

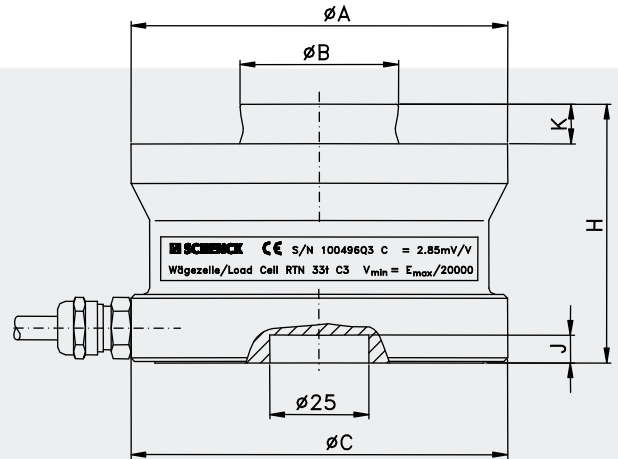

#### Technical Data

Rated Capacity $E_{max}$ t	Safe Load Limit $L_l$ t	Breaking Load $L_d$ t	Nominal displacement $h_n$ mm	Dead weight kg
1	1.7	4	0.13	0.6
2.2	4	9	0.12	0.6
4.7	8	19	0.12	0.7
10	17	40	0.17	1.2
15	28	60	0.18	1.3
22	38	90	0.21	1.3
33	58	130	0.25	2.1
47	80	190	0.33	4.3
68	120	270	0.35	4.8
100	170	400	0.45	7.0
150	250	600	0.57	8.6
220	380	900	0.67	22.0
330	580	1200	0.85	29.0
470	700	1500	1.00	50.0

#### Dimensions

Type	Dimensions (mm)							
	RTN	A	B	C	D	H	K	J
1 t	49	20	60	53	43	7.5	-	-
2.2 t	49	20	60	53	43	7.5	-	-
4.7 t	49	20	60	53	43	7.5	-	-
10 t	73	30	75	-	50	6.5	7	-
15 t	75	30	75	-	50	6.5	7	-
22 t	75	30	75	-	50	6.5	7	-
33 t	95	40	95	-	65	10	7	-
47 t	130	60	130	-	75	14	7	-
68 t	130	60	130	-	85	14	7	-
100 t	150	70	150	-	90	16	7	-
150 t	150	70	150	-	100	16	7	-
220 t	225	100	225	-	130	24	10	-
330 t	225	100	225	-	145	24	10	-
470 t	270	120	270	-	170	28	10	-

Admissible static side load  $L_q = 0.5 (E_{max} - 0.8 L_z)$ , but no higher than  $L_{qmax} = 0.3 E_{max}$ ;  $E_{max}$  = rated capacity;  
 $L_z$  = load in measuring direction

Admissible dynamic load to DIN 50100: 70%  $E_{max}$ . Dynamic load value must not exceed  $E_{max}$ .

## Technical Data

Rated capacity	$E_{max}$	1 t – 470 t		1 t – 100 t	
Accuracy class		0.05	C3	C5 / C4 Mi 7.5	Reference
Sensitivity	$C_n$	2,85 mV/V $\pm$ 2,85 $\mu$ V/V			
Combined error	$F_{comb}$	0.05 %	0.02 %	0.01 %	$C_n$
Minimum dead load output return	$F_{dr}$	$\pm$ 0.03 %	$\pm$ 0.016 %	$\pm$ 0.006 %	$C_n$
Creep (30 m)	$F_{cr}$	$\pm$ 0.04 %	$\pm$ 0.024 %	$\pm$ 0.009 %	$C_n$
Temperature effect on zero sensitivity per 10 K	$TK_0$	$\pm$ 0.03 % $\pm$ 0.05 %	$\pm$ 0.007 % $\pm$ 0.02 %	$\pm$ 0.0058 % $\pm$ 0.02 %	$C_n, B_{tn}$ $C_n, B_{tu}$
Temperature effect on sensitivity per 10 K	$TK_c$	$\pm$ 0.05 % $\pm$ 0.07 %	$\pm$ 0.008 % $\pm$ 0.02 %	$\pm$ 0.0062 % $\pm$ 0.02 %	$C_n, B_{tn}$ $C_n, B_{tu}$
Maximum number of scale intervalls	$n_{LC}$		3000	5000	
For multi-divisional scales:	Z			7500	
Minimum load cell verification intervall	$V_{min}$		$E_{max}/20000$	$E_{max}/24000$	
Max. utilisation range	$B_{amax}$	$B_{amax} = E_{max}$			
Input resistance	$R_e$	$4450 \Omega \pm 100 \Omega$			$T_r$
Output resistance	$R_a$	$4010 \Omega \pm 2 \Omega$	$4010 \Omega \pm 0.5 \Omega$		$T_r$
Zero signal	$S_0$	$\pm 1\%$			$C_n$
Max. supply voltage	$U_{smax}$	60V			
Nominal temperature range	$B_{tn}$	-10°C to +40°C			
Service temperature range	$B_{tu}$	-40°C to +80°C, Option to +110°C			
Reference temperature	$T_r$	22°C			
Storage temperature range	$B_{ts}$	-50°C to +85°C			
Protection class		IP 68, 1m / 100hr; (Option 110°C: IP 66)			
Cable specification		TPE (grey) $\varnothing$ 6.5 mm, silicone and halogen free, -30°C to +150°C, Length 5 m for RTN 1 - 15 t and RTN 150 - 470 t Length 15 m for RTN 22 - 100 t			
Colour code		Black: input + / blue: input - Red: output + / white: output - Green-yellow: screening			
Material		Stainless steel			
Corrosion protection		see Spec Sheet DDP 8483 "Chemical resistance of RT Load Cells"			

**Order No.**

Variants	Accuracy class		
	0.05	C3	C5 / C4Mi 7.5
RTN 1 t	D726173.04	D726173.02	D726173.10
RTN 2.2 t	D726174.04	D726174.02	D726174.10
RTN 4.7 t	D726175.04	D726175.02	D726175.10
RTN 10 t	D726176.04	D726176.02	D726176.10
RTN 15 t	D726177.04	D726177.02	D726177.10
RTN 22 t	D724781.04	D724781.02	D724781.10
RTN 33 t	D724754.04	D724754.02	D724754.10
RTN 47 t	D724782.04	D724782.02	D724782.10
RTN 68 t	D724783.04	D724783.02	D724783.10
RTN 100 t	D724784.04	D724784.02	D724784.10
RTN 150 t	D726178.04	D726178.02	
RTN 220 t	D726179.04	D726179.02	
RTN 330 t	D726180.04	D726180.02	
RTN 470 t	D726181.04	D726181.02	

**Order No. Version ATEX variants**

Variant ATEX 2GD,  
 Gas-Ex category II 2 G; EEx ia IIC T4 / T6 (Zone 1)  
 Dust-Ex category II 2 D; IP68; T80°C (Zone 21)

	Accuracy class		
	0.05 2GD	C3 2GD	C5 / C4MI 7,5 2GD
	Variant .03	Variant .01	Variant .09

Note: In category 2G (zone 1), the 2GD-load cells are operated intrinsically safe (i.e. with barriers).  
 In category 2D (zone 21) this is, however, not necessary.

Variant ATEX 3GD (zone 2 and 22)

	Accuracy class		
	0.05 3GD	C3 3GD	C5 / C4MI 7,5 3GD
	Variant .53	Variant .51	Variant .55

**Example for ordering:** 47t, accuracy class C3, ATEX category 3GD. Type RTN 47t C3 3GD;  
 Order No. D724782.51

<b>Option:</b> <ul style="list-style-type: none"> <li>■ Variant for service temperature range of up to 110°C</li> <li>■ Customized cable length</li> <li>■ Special corrosion protection</li> <li>■ Connection cable PVC</li> </ul>	<b>Accessories:</b> Elastomer mount, Compact mounts, Pendulum mounts, Fixed bearing
--	--

**Schenck Process GmbH**  
 Pallaswiesenstr. 100  
 64293 Darmstadt, Germany  
 Phone: +49 6151 1531-1216  
 Fax: +49 6151 1531-1172  
 sales@schenckprocess.com  
 www.schenckprocess.com