



schenckAccuRate



**SF Model 5000  
Streamout Feeder**

## SolidsFlow® Model 5000 Streamout Feeder

Spreading a uniform curtain-like flow of material across a relatively wide area is not an easy job for most feeders. Many feeders operate at less than 200 rpm, producing an erratic, pulsating flow, which affects accuracy and uniformity.

Schenck AccuRate's SolidsFlow® Model 5000 Streamout Feeder delivers a controlled, continuously uniform flow across the entire length of the feed tray outlet. The result is consistent application and product quality.

The SolidsFlow® Model 5000 Streamout Feeder incorporates a unique one-piece feed tray that is designed to control and accommodate the material's flow characteristics. The tray works with the material's natural angle of repose preventing any flow when the drive is turned off. No spillage. No run-on.

When engaged, a high frequency horizontal motion applied to the feed tray produces a consistent, uniform flow. Material shears across the total cross section of the hopper. There is no segregation, compaction, funnel flow, or other material flow problems.

### FEATURES & BENEFITS:

- Streams from 8" to 66" wide.  
Feeders can be combined to produce wider streams.
- Instant cut-off for optimal batch accuracy.  
No cut-off gates required.
- Reliable, controlled flow without flow-aid devices.
- Lower power requirements.  
Less operating cost.
- No moving parts. Few spare parts.
- Simple design. Easy installation.

### SPREADING, TOPPING, COATING, AND SPRINKLING APPLICATIONS FOR THE STREAMOUT FEEDER:

- Food seasonings and flavorings.
- Abrasive grit.
- Roofing granules.
- Super-absorbent polymers.
- Dispersing material into slurries.
- Mold filling.



*Gap adjustment can be easily made by simply using a wrench.*

**Specifications**

**For more information, please contact us at 1-800-558-0184 or Fax: 262-473-4384  
E-mail: [mktg@accuratefeeders.com](mailto:mktg@accuratefeeders.com) Web site: [www.accuratefeeders.com](http://www.accuratefeeders.com)**

# SF Model 5000 Streamout Feeder

# Specifications

## Streamout Feeder Sized 8" - 16" Wide

### NOTES:

- ONE VIBRATORY ELECTROMAGNETIC DRIVE:**  
115 VAC, 1PH, 60 Hz, 80 Watts, 4A per drive.  
220 VAC, 1PH, 60 Hz, 80 Watts, 2A per drive.  
Electromagnetic drives are dust proof, splash proof, and can be cleaned with steam or water.
- SYSTEM ELECTRICAL SERVICE REQUIREMENTS:**  
Service recommendation 15 amps, 115 VAC, 60 Hz, full load current 4.0 amps.
- FLEXIBLE CONNECTIONS:**  
A flexible connector is located between the stationary hopper and feed tray.
- FEEDER COVER:**  
Manual cover with grab handle(s) standard. For auto refill cover(s) with vent(s) consult factory.
- PLATFORMS:**  
Platform must be used with load cells for gravimetric applications. Platform may be used for volumetric applications using volumetric brackets in place of load cells.
- LOAD CELL CAPACITY CHOICES FOR THIS SIZE ARE:**  
50 Kg/110 lbs (150 Kg/331 lbs total capacity).  
100 Kg/220 lbs (300 Kg/661 lbs total capacity).  
200 Kg/441 lbs (600 Kg/1,323 lbs total capacity).

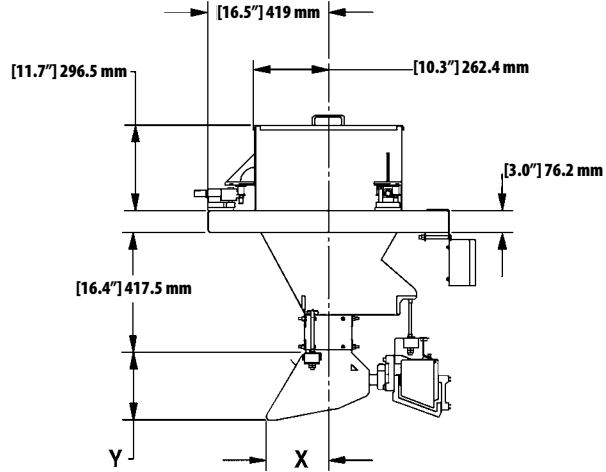

TRAY END	X DIM inch	X DIM mm	Y DIM inch	Y DIM mm
SHORT OVERLAP, 5 DEG	7.2	182	8.6	219
LONG OVERLAP, 5 DEG	8.6	219	8.7	222
SHORT OVERLAP, 10 DEG	7.1	180	9.3	235
LONG OVERLAP, 10 DEG	8.5	216	9.5	242

WIDTHS (INCHES)		8-10	11-13	14-16
DEAD LOAD (LBS)	FEED TRAY	26	31	36
	ECCENTRIC VIBRATORS	48	48	48
	REFILL HOPPER EXTENSION	57	64	70
	COVER ASSEMBLY	5	7	8
	TOTAL (LBS)	136	150	162
	PLATFORM	77	85	105
	WEIGH MODULES	10	10	10
	ELECTRICAL ENCLOSURE	45	45	45
	TOTAL SYSTEM LBS	268	290	322
	TOTAL SYSTEM KG	122	131	147
VOLUME CUBIC FEET	2.6	3.6	4.6	
VOLUME LITERS	74	102	129	

## Streamout Feeder Sized 17" - 24" Wide

### NOTES:

- TWO VIBRATORY ELECTROMAGNETIC DRIVES:**  
115 VAC, 1PH, 60 Hz, 80 Watts, 4A per drive.  
220 VAC, 1PH, 60 Hz, 80 Watts, 2A per drive.  
Electromagnetic drives are dust proof, splash proof, and can be cleaned with steam or water.
- SYSTEM ELECTRICAL SERVICE REQUIREMENTS:**  
Service recommendation 15 amps, 115 VAC, 60 Hz, full load current 8.0 amps.
- FLEXIBLE CONNECTIONS:**  
A flexible connector is located between the stationary hopper and feed tray.
- FEEDER COVER:**  
Manual cover with grab handle(s) standard. For auto refill cover(s) with vent(s) consult factory.
- PLATFORMS:**  
Platform must be used with load cells for gravimetric applications. Platform may be used for volumetric applications using volumetric brackets in place of load cells.
- LOAD CELL CAPACITY CHOICES FOR THIS SIZE ARE:**  
100 Kg/220 lbs (300 Kg/661 lbs total capacity).  
200 Kg/441 lbs (600 Kg/1,323 lbs total capacity).

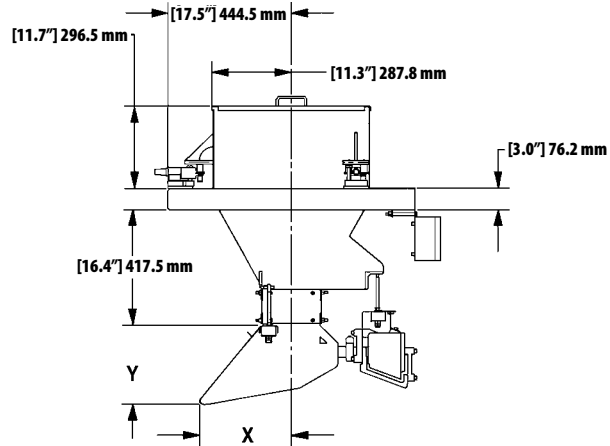

TRAY END	X DIM inch	X DIM mm	Y DIM inch	Y DIM mm
SHORT OVERLAP, 5 DEG	8.8	223	9.6	244
MID OVERLAP, 5 DEG	11.2	284	9.8	249
LONG OVERLAP, 5 DEG	13.1	334	10.0	254
SHORT OVERLAP, 10 DEG	8.7	220	10.4	263
MID OVERLAP, 10 DEG	11.1	281	10.8	275
LONG OVERLAP, 10 DEG	13.0	331	11.2	284

WIDTHS (INCHES)		17-19	20-22	23-24
DEAD LOAD (LBS)	FEED TRAY	42	47	50
	ECCENTRIC VIBRATORS	96	96	96
	REFILL HOPPER EXTENSION	77	83	88
	COVER ASSEMBLY	10	12	13
	TOTAL (LBS)	225	238	247
	PLATFORM	84	89	105
	WEIGH MODULES	10	10	10
	ELECTRICAL ENCLOSURE	45	45	45
	TOTAL SYSTEM LBS	364	382	407
	TOTAL SYSTEM KG	165	173	184
VOLUME CUBIC FEET	6.2	7.2	7.8	
VOLUME LITERS	175	203	222	

## Streamout Feeder Sized 25" - 38" Wide

### NOTES:

- THREE VIBRATORY ELECTROMAGNETIC DRIVES:**  
115 VAC, 1PH, 60 Hz, 80 Watts, 4A per drive.  
220 VAC, 1PH, 60 Hz, 80 Watts, 2A per drive.  
Electromagnetic drives are dust proof, splash proof, and can be cleaned with steam or water.
- SYSTEM ELECTRICAL SERVICE REQUIREMENTS:**  
Service recommendation 15 amps, 115 VAC, 60 Hz, full load current 12.0 amps.
- FLEXIBLE CONNECTIONS:**  
A flexible connector is located between the stationary hopper and feed tray.
- FEEDER COVER:**  
Manual cover with grab handle(s) standard. For auto refill cover(s) with vent(s) consult factory.
- PLATFORMS:**  
Platform must be used with load cells for gravimetric applications. Platform may be used for volumetric applications using volumetric brackets in place of load cells.
- LOAD CELL CAPACITY CHOICES FOR THIS SIZE ARE:**  
100 Kg/220 lbs (300 Kg/661 lbs total capacity).  
200 Kg/441 lbs (600 Kg/1,323 lbs total capacity).  
500 Kg/1,102 lbs (1,500 Kg/3,307 lbs total capacity).

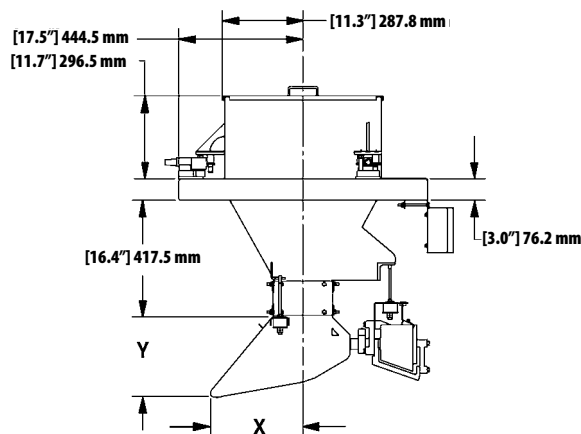

TRAY END	X DIM inch	X DIM mm	Y DIM inch	Y DIM mm
SHORT OVERLAP, 5 DEG	8.8	223	9.6	244
MID OVERLAP, 5 DEG	11.2	284	9.8	249
LONG OVERLAP, 5 DEG	13.1	334	10.0	254
SHORT OVERLAP, 10 DEG	8.7	220	10.4	263
MID OVERLAP, 10 DEG	11.1	281	10.8	275
LONG OVERLAP, 10 DEG	13.0	331	11.2	284

WIDTHS (INCHES)		25-29	30-33	34-38
DEAD LOAD (LBS)	FEED TRAY	59	66	75
	ECCENTRIC VIBRATORS	144	144	144
	REFILL HOPPER EXTENSION	98	107	118
	COVER ASSEMBLY	15	17	20
	TOTAL (LBS)	316	334	357
	PLATFORM	83	87	105
	WEIGH MODULES	10	10	10
	ELECTRICAL ENCLOSURE	45	45	45
	TOTAL SYSTEM LBS	454	476	517
	TOTAL SYSTEM KG	206	216	234
VOLUME CUBIC FEET	9.5	10.8	12.4	
VOLUME LITERS	268	305	351	

## Streamout Feeder Sized 39" - 53" Wide

### NOTES:

- FOUR VIBRATORY ELECTROMAGNETIC DRIVES:**  
115 VAC, 1PH, 60 Hz, 80 Watts, 4A per drive.  
220 VAC, 1PH, 60 Hz, 80 Watts, 2A per drive.  
Electromagnetic drives are dust proof, splash proof, and can be cleaned with steam or water.
- SYSTEM ELECTRICAL SERVICE REQUIREMENTS:**  
Service recommendation 20 amps, 115 VAC, 60 Hz, full load current 16.0 amps.
- FLEXIBLE CONNECTIONS:**  
A flexible connector is located between the stationary hopper and feed tray.
- FEEDER COVER:**  
Manual cover with grab handle(s) standard. For auto refill cover(s) with vent(s) consult factory.
- PLATFORMS:**  
Platform must be used with load cells for gravimetric applications. Platform may be used for volumetric applications using volumetric brackets in place of load cells.
- LOAD CELL CAPACITY CHOICES FOR THIS SIZE ARE:**  
200 Kg/441 lbs (600 Kg/1,323 lbs total capacity).  
500 Kg/1,102 lbs (1,500 Kg/3,307 lbs total capacity).

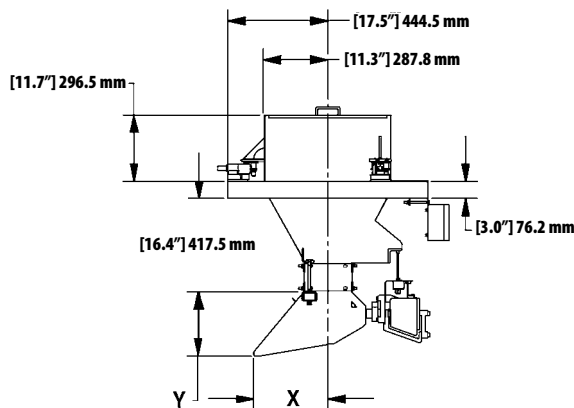

TRAY END	X DIM inch	X DIM mm	Y DIM inch	Y DIM mm
SHORT OVERLAP, 5 DEG	8.8	223	9.6	244
MID OVERLAP, 5 DEG	11.2	284	9.8	249
LONG OVERLAP, 5 DEG	13.1	334	10.0	254
SHORT OVERLAP, 10 DEG	8.7	220	10.4	263
MID OVERLAP, 10 DEG	11.1	281	10.8	275
LONG OVERLAP, 10 DEG	13.0	331	11.2	284

WIDTHS (INCHES)		39-43	44-48	49-53
DEAD LOAD (LBS)	FEED TRAY	84	92	101
	ECCENTRIC VIBRATORS	192	192	192
	REFILL HOPPER EXTENSION	128	139	150
	COVER ASSEMBLY	23	25	28
	TOTAL (LBS)	427	448	471
	PLATFORM	85	88	105
	WEIGH MODULES	10	10	10
	ELECTRICAL ENCLOSURE	45	45	45
	TOTAL SYSTEM LBS	567	591	631
	TOTAL SYSTEM KG	257	269	286
VOLUME CUBIC FEET	14.0	15.6	17.3	
VOLUME LITERS	397	443	489	

# SF Model 5000 Streamout Feeder

## Streamout Feeder Sized 54" - 66" Wide

### NOTES:

- FIVE VIBRATORY ELECTROMAGNETIC DRIVES:**  
115 VAC, 1PH, 60 Hz, 80 Watts, 4A per drive.  
220 VAC, 1PH, 60 Hz, 80 Watts, 2A per drive.  
Electromagnetic drives are dust proof, splash proof, and can be cleaned with steam or water.
- SYSTEM ELECTRICAL SERVICE REQUIREMENTS:**  
Service recommendation 20 amps, 115 VAC, 60 Hz, full load current 20.0 amps.
- FLEXIBLE CONNECTIONS:**  
A flexible connector is located between the stationary hopper and feed tray.
- FEEDER COVER:**  
Manual cover with grab handle(s) standard. For auto refill cover(s) with vent(s) consult factory.
- PLATFORMS:**  
Platform must be used with load cells for gravimetric applications. Platform may be used for volumetric applications using volumetric brackets in place of load cells.
- LOAD CELL CAPACITY CHOICES FOR THIS SIZE ARE:**  
200 Kg/441 lbs (600 Kg/1,323 lbs total capacity).  
500 Kg/1,102 lbs (1,500 Kg/3,307 lbs total capacity).

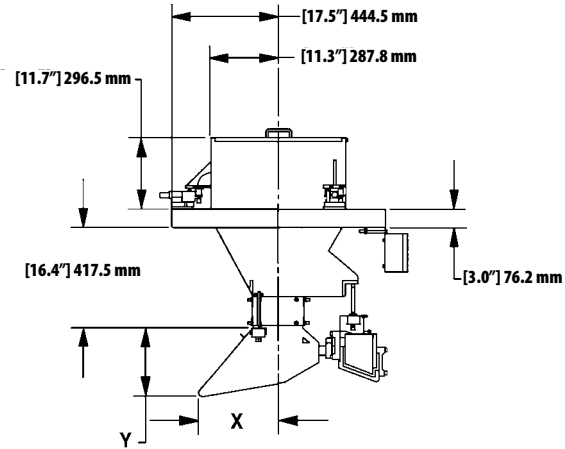

TRAY END	X DIM inch	X DIM mm	Y DIM inch	Y DIM mm
SHORT OVERLAP, 5 DEG	8.8	223	9.6	244
MID OVERLAP, 5 DEG	11.2	284	9.8	249
LONG OVERLAP, 5 DEG	13.1	334	10.0	254
SHORT OVERLAP, 10 DEG	8.7	220	10.4	263
MID OVERLAP, 10 DEG	11.1	281	10.8	275
LONG OVERLAP, 10 DEG	13.0	331	11.2	284

	54-57	58-61	62-66
<b>WIDTHS (INCHES)</b>			
FEED TRAY	108	110	118
ECCENTRIC VIBRATORS	240	240	240
REFILL HOPPER EXTENSION	158	160	170
COVER ASSEMBLY	30	32	35
<b>TOTAL (LBS)</b>	<b>536</b>	<b>542</b>	<b>563</b>
PLATFORM	177	186	197
WEIGH MODULES	10	10	10
ELECTRICAL ENCLOSURE	45	45	45
<b>TOTAL SYSTEM LBS</b>	<b>768</b>	<b>783</b>	<b>815</b>
<b>TOTAL SYSTEM KG</b>	<b>349</b>	<b>355</b>	<b>370</b>
VOLUME CUBIC FEET	18.6	19.9	21.5
VOLUME LITERS	527	563	609

# Specifications

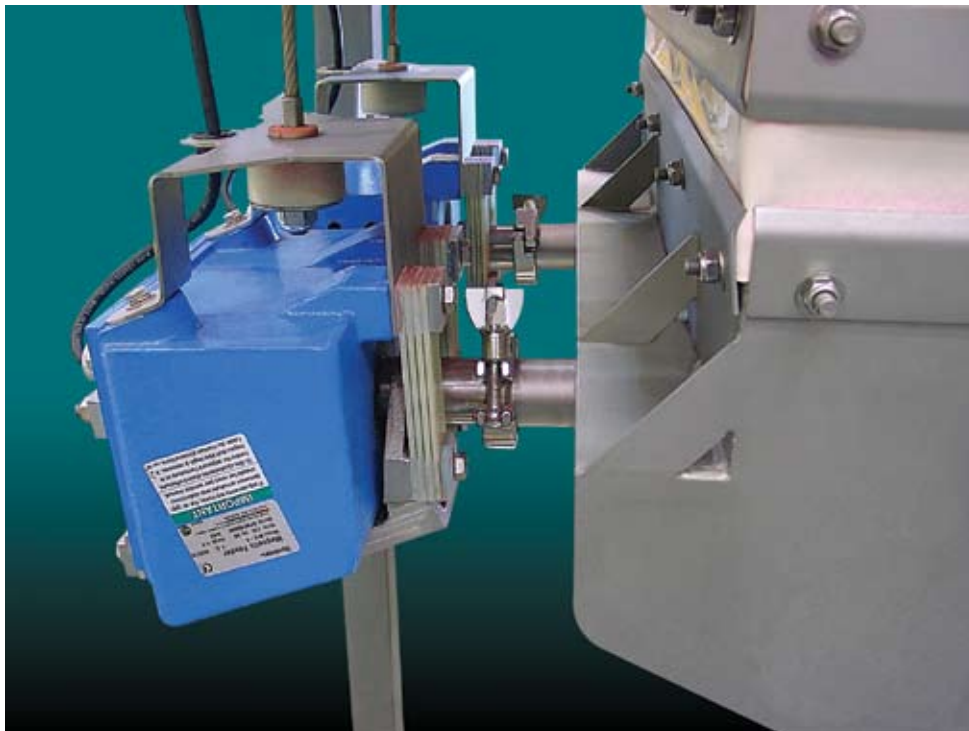

Tri-clover clamps provide trouble-free disconnection of the drives.